

Eccentric Screw Pumps

Series AE.N Design RG

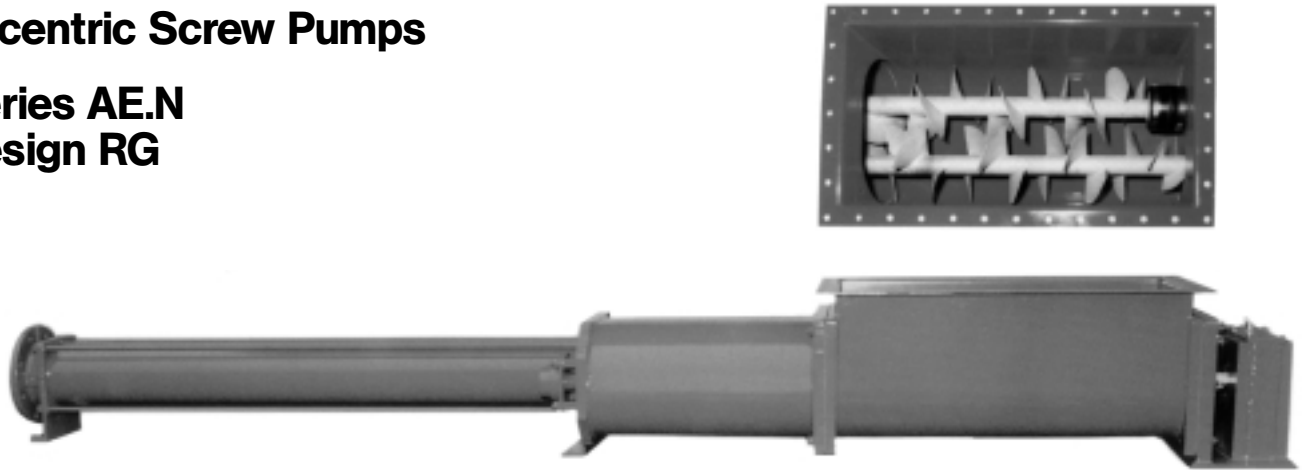

Application

For pumping highly viscous to no more flowable, neutral or aggressive, uncontaminated or abrasive liquids as well as products containing gases also with fibrous and solid material. Here, the screw shafts can additionally serve as mixing device.

Main fields of application

Waste water and waste water treatment engineering, the chemical and petro-chemical industries, the paper and cellulose industries, the soap and fats industry, the paint industry, the food and beverage industry, the plastics industry, ceramics, agriculture, the sugar industry etc.

Operation

Rotary self-priming positive displacement pump the pumping elements of which are the rotating eccentric screw (rotor), the fixed stator and the feeding screws.

In any cross sectional plane, rotor and stator are in contact with one another at two points, and along the length of the pumping elements these points form two lines of seal. The material contained in the sealed enclosed cavities which are formed as the rotor turns is displaced axially and with complete continuity from the suction to the delivery end of the pump. Despite the fact that the rotor rotates, no turbulence is produced. The constant volume of the enclosed cavities means that there are no pressurizing forces and thus guarantees a low-surge pumping action which is not at all severe on the material being pumped.

Design features

The outlet section, stator and suction casing are held together by external connecting screws (tie rods).

In case of all sizes, the suction casing has a feeding hopper the vertical wall surfaces of which prevent deposits of the material to be conveyed. The rectangular connecting flange is provided for the attachment of filling hoppers.

The particularly large engaging feeding or mixing screws are dimensioned so that an optimum mixing effect and a reliable filling of the conveying elements via the particularly long stuffing box housing is effected.

The stator which is vulcanized into a tube or jacket casing (uniform elastomer wall thickness) is provided at both ends with external collars vulcanized to it which provide a safe seal from the suction casing and outlet section and also protect the stator casing against corrosion.

The drive shaft is carried in bearings in the bearing housing. The drive torque is transmitted to the rotor via the drive shaft, pump shaft and joint shaft and, via a tooth gear step, to the screw shaft. The joint shaft terminates at both ends in pin-type universal joints which are encapsulated to form a liquid-tight seal. These pin-type universal joints are of particularly simple and rugged design and are able to withstand the eccentric movement of the rotor without any difficulty.

Shaft seals

The shaft seals consist of packing glands on the drive side and a running gear seal on the stator side.

Bearings

The shafts are secured in sturdy and maintenance-free bearings. The bearings are lifetime-lubricated deep groove ball bearings.

Technical characteristics

The output, permitted speed range and drive power required can be taken from the selection chart on page 3 or from the separate individual pump characteristics.

		single-stage	two-stage	four-stage
Flow rate	Q l/min up to	500		
Temperature of liquid pumped	t °C ① up to	150		
Differential pressure	single-stage	6 ②	-	-
	two-stage		12 ③	-
	four-stage		-	16(20 ⑥)
Pump discharge pressure	p _d bar up to	16 (25 ⑥)		
Suction obtainable	p _s bar up to	0.5 ④		
Viscosity	η mPa s up to	1,000,000 ④		
Permissible solids content	% by vol. up to	95 ⑤		
Permissible casing pressure, suction casing	p _z bar up to	0.5		
Dry substance content	% ④ up to	45		

The mentioned performance data are to be considered as a product and performance abstract only. The particular operating limits can be taken from the quotation or order acknowledgement.

Max. permissible grain sizes and fibre lengths

Pump size	100	200	380	750	1450	2700
max. grain size mm	3.8	5	6.8	9.5	14	20
max. fibre length mm	48	60	79	98	130	210

Increases in solid content and grain size mean that the speed of the pump must be reduced.

- ① Depending on the liquid pumped and the elastomers used.
- ② 12 bar for stator with uniform elastomer wall thickness.
- ③ 16 (20 ⑥) bar for stator with uniform elastomer wall thickness.
- ④ Depending on liquid pumped, speed and pump size.
- ⑤ Depending on pump size as well as kind and size of solids.
- ⑥ Possible for sizes 380, 750, 1450, 2700.

Exchangeability of components

The components of all eccentric screw pumps are manufactured according to a modular construction. Thus, even when using pumps of various series and types in one plant, a simple and budget-priced spare parts stocking is assured.

Drivers

For possible types of drive see page 10.

Drivers produced by any manufacturer can be used. Technical characteristics and dimensions should be taken from the documentation issued by the manufacturers.

Installation

AE.N...-RG pumps are installed horizontally.

The pump and driver are connected together via a flexible coupling and are mounted on a common base plate. Dimensions of assemblies available on request.

Performance chart

To give a rough indication of the appropriate pump size and speed as a function of the required output and the nature of the liquid to be pumped. $v_{g,m}$ = mean rubbing speed of rotor in stator.

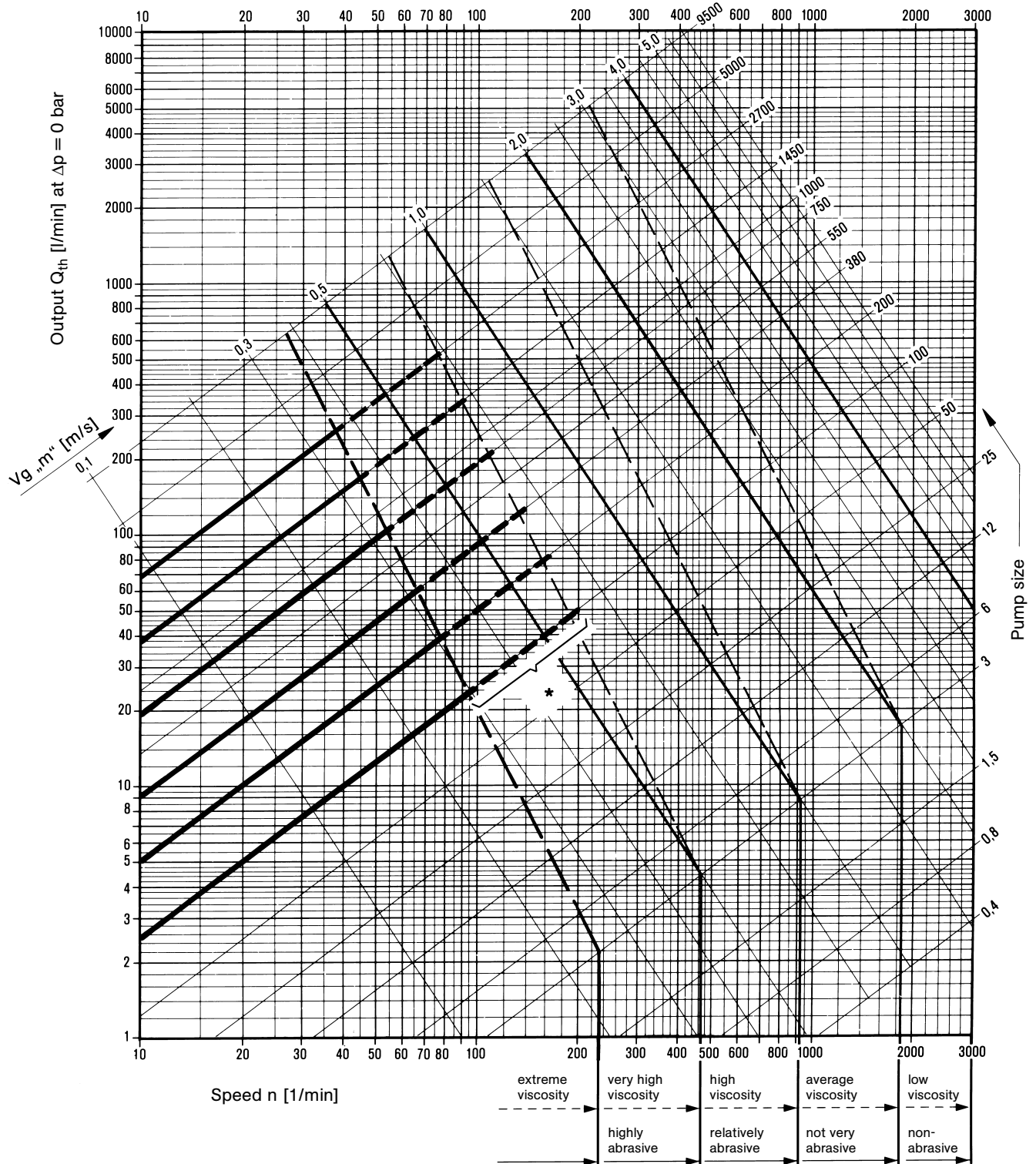

* Largely depending on the fluid to be pumped. Please inquire.

Information on performance ranges not covered by the AE.N...-RG series can be found on the back cover of this brochure or in the separate brochures dealing with the other series. For exact performance data, see the individual pump characteristics.

Type coding

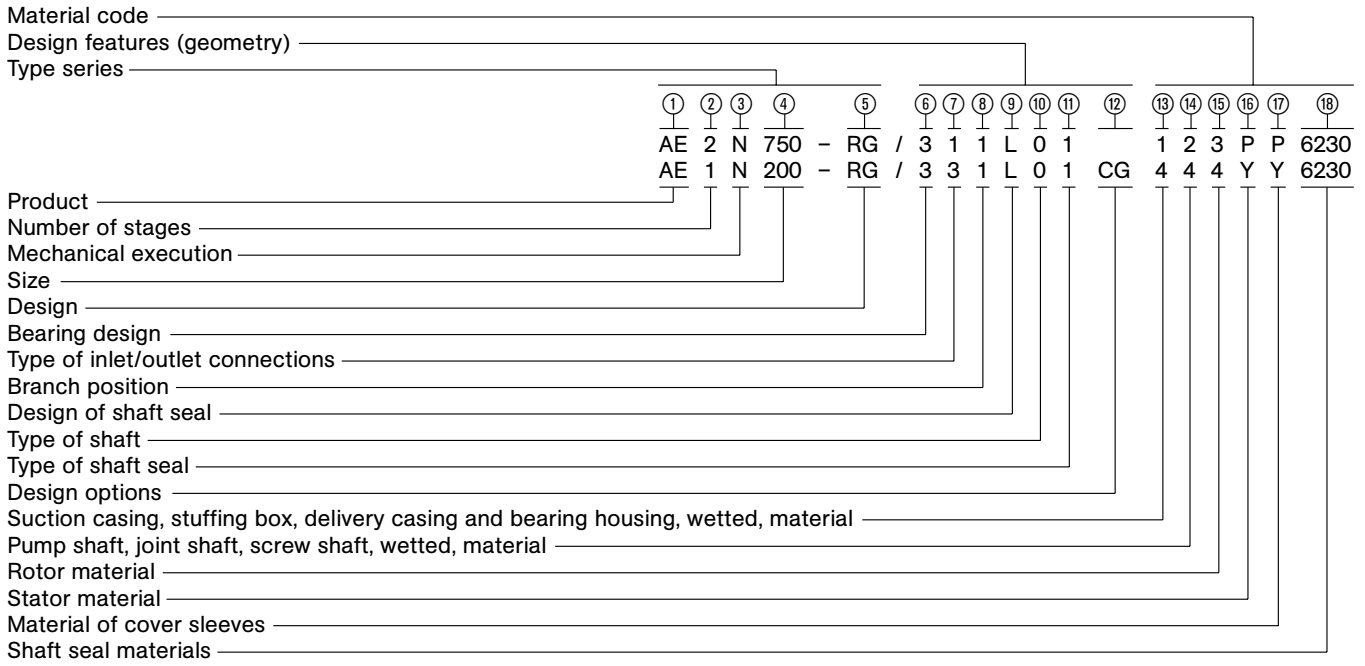

Explanatory notes on the type coding:

Position in type coding	Designation	Design									
①	Product	ALLWEILER eccentric screw pump									
②	Number of stages	1 = single-stage up to Δp 6 bar (Δp 12 bar for stator with uniform elastomer wall thickness), 2 = two-stage up to Δp 12 bar (Δp 16 (20) bar for stator with uniform elastomer wall thickness), 2+2; 4 = 2+2 stage; four-stage up to Δp 16 (20) bar									
③	Mechanical execution	N = rated for Δp 16 (20) bar									
④	Size	Possible sizes: 100, 200, 380, 750, 1450, 2700 The numbers indicate the theoretic flow rate in l/min with $n = 400$ 1/min and $\Delta p = 0$ bar									
⑤	Design	RG = Snap type with internal gear bearing									
⑥	Bearing design	3 = hose-proof, bearing with rotary shaft seal or sealing cap. All bearings lifetime-lubricated.									
⑦	Type of inlet/outlet connections	Suction casing connection according to dimensional drawing, page 9 Type of outlet connection 1 = DIN flanges 3 = ANSI flanges X = Special-type suction casing connection and/or outlet connection] according to dimensional drawing, page 9									
⑧	Branch position	1 - For the position, please see drawing on page 9									
⑨	Design of shaft seal	L = Packing glands on drive side and a running gear seal on stator side									
⑩	Type of shaft	0 = Shaft hard-chrome-plated in the packing region without shaft wear sleeve									
⑪	Type of shaft seal	Stuffing boxes 1 = Stuffing box of standard design (without lantern ring/without flushing ring)									
⑫	Design options	<table border="0" style="width: 100%;"> <tr> <td style="width: 50%; vertical-align: top;"> Stators with non-uniform elastomer wall thickness (all elastomers) N M H T] Thermal expansion clearance as a function of the temperature of the fluid pumped </td> <td style="width: 50%; vertical-align: top;"> Stators with uniform elastomer wall thickness (all elastomers) D E F R] Thermal expansion clearance as a function of the temperature of the fluid pumped </td> </tr> <tr> <td style="vertical-align: top;"> C = Rotor hard-chrome plated Y = Rotor ductile hard-chrome plated Z = Rotor spray metal-coated </td> <td style="vertical-align: top;"> B = Stator adjustable G = Stator with uniform elastomer wall thickness Q = Mixing screws X = Other designs </td> </tr> </table>	Stators with non-uniform elastomer wall thickness (all elastomers) N M H T] Thermal expansion clearance as a function of the temperature of the fluid pumped	Stators with uniform elastomer wall thickness (all elastomers) D E F R] Thermal expansion clearance as a function of the temperature of the fluid pumped	C = Rotor hard-chrome plated Y = Rotor ductile hard-chrome plated Z = Rotor spray metal-coated	B = Stator adjustable G = Stator with uniform elastomer wall thickness Q = Mixing screws X = Other designs					
Stators with non-uniform elastomer wall thickness (all elastomers) N M H T] Thermal expansion clearance as a function of the temperature of the fluid pumped	Stators with uniform elastomer wall thickness (all elastomers) D E F R] Thermal expansion clearance as a function of the temperature of the fluid pumped										
C = Rotor hard-chrome plated Y = Rotor ductile hard-chrome plated Z = Rotor spray metal-coated	B = Stator adjustable G = Stator with uniform elastomer wall thickness Q = Mixing screws X = Other designs										
⑬	Suction casing, stuffing box, delivery casing and bearing housing, wetted, material	1 = cast iron EN-GJL-250 / GS-45 / St. 4 = 1.4408/1.4571 X = Special materials									
⑭	Pump shaft, joint shaft, screw shaft, wetted, material	2 = 1.4301/1.4571 4 = 1.4571 X = Special materials									
⑮	Rotor materials	3 = 1.2436/1.2379 4 = 1.4571 X = Special materials, e.g. other metals, plastic materials									
⑯	Stator materials	<table border="0" style="width: 100%;"> <tr> <td style="width: 33%;">WB = Soft natural rubber</td> <td style="width: 33%;">Y = Hypalon</td> <td style="width: 33%;">SL = Silicon light</td> </tr> <tr> <td>P = Perbunan N</td> <td>V = Viton</td> <td>PU = Polyurethan</td> </tr> <tr> <td>PL = Perbunan light</td> <td>HP = Perbunan hydrogenated</td> <td>X = Special materials</td> </tr> </table>	WB = Soft natural rubber	Y = Hypalon	SL = Silicon light	P = Perbunan N	V = Viton	PU = Polyurethan	PL = Perbunan light	HP = Perbunan hydrogenated	X = Special materials
WB = Soft natural rubber	Y = Hypalon	SL = Silicon light									
P = Perbunan N	V = Viton	PU = Polyurethan									
PL = Perbunan light	HP = Perbunan hydrogenated	X = Special materials									
⑰	Materials of cover sleeves	<table border="0" style="width: 100%;"> <tr> <td style="width: 33%;">P = Perbunan N</td> <td style="width: 33%;">Y = Hypalon</td> <td style="width: 33%;">X = Special materials</td> </tr> <tr> <td>PL = Perbunan light</td> <td>V = Viton</td> <td></td> </tr> </table>	P = Perbunan N	Y = Hypalon	X = Special materials	PL = Perbunan light	V = Viton				
P = Perbunan N	Y = Hypalon	X = Special materials									
PL = Perbunan light	V = Viton										
⑱	Shaft seal materials	Stuffing box: 5846 = Ramie fibre with PTFE impregnation, asbestos-free 6426 = Aramid endless fibre with PTFE impregnation, asbestos-free 6230 = Graphite-incorporated PTFE with sliding agent, asbestos-free X = Other packing materials									

Sectional drawing and parts list

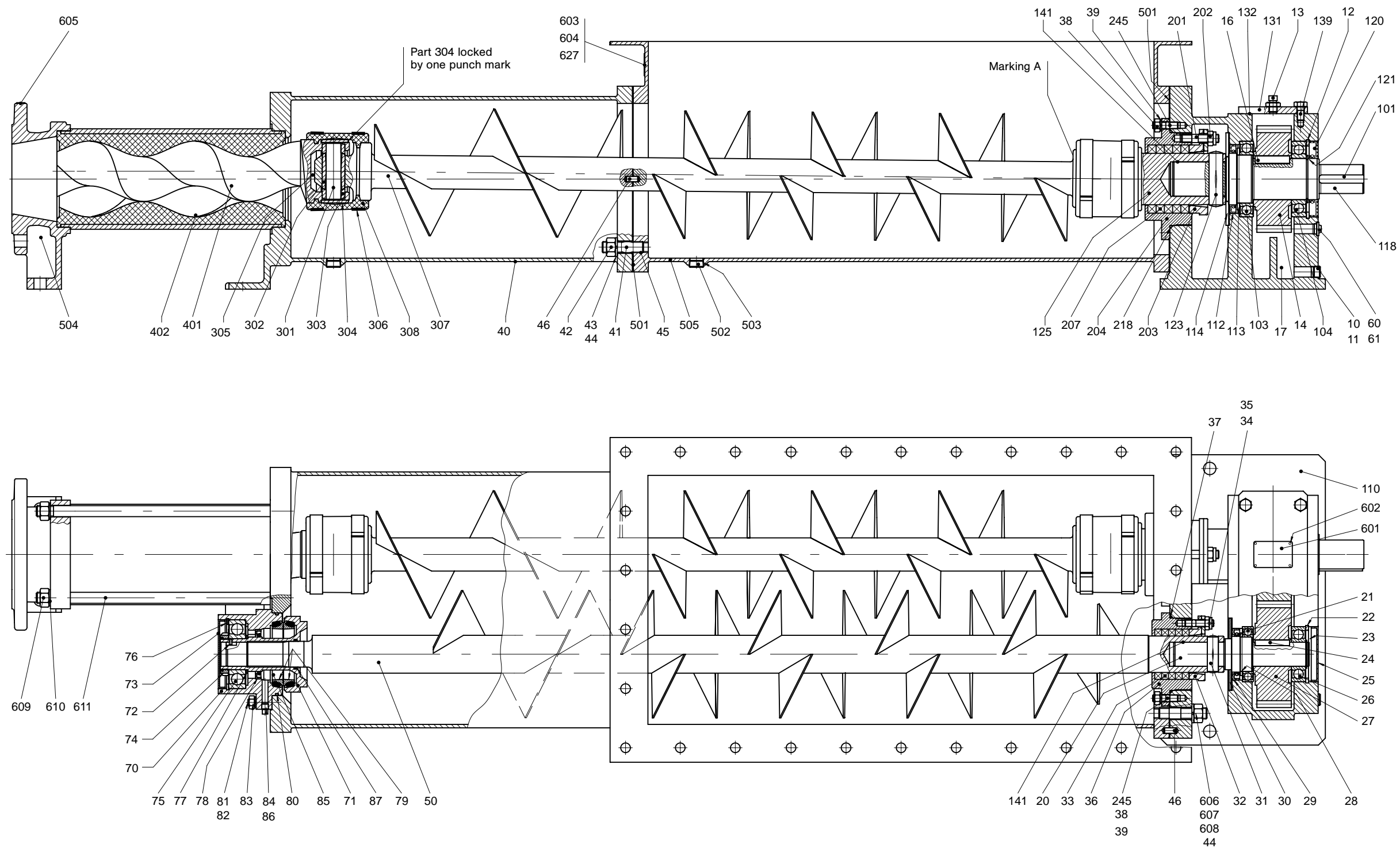

Part No.	Denomination	Part No.	Denomination	Part No.	Denomination	Part No.	Denomination	Part No.	Denomination	Part No.	Denomination	Part No.	Denomination
10	Screw plug	27	Spur wheel	41	Stud	75	Radial bearing	103	Radial bearing	141	Lubricating paste	307	Joint shaft
11	Sealing tape	28	Spacer ring	42	Hexagon nut	76	Circlip	104	Axial bearing	201	Stud	308	Cover sleeve
12	Circlip	29	Lip seal	43	Spring ring	77	Spacer ring	110	Bearing housing	202	Self-locking nut	401	Rotor
13	Venting filter	30	Thrower	44	Washer	78	Lip seal	112	Lip seal	203	Gland half	402	Stator
14	Spur wheel	31	Drive-type pin	45	Screw sealing agent	79	Running gear seal	113	Spacer ring	204	Stuffing box housing	501	Suction casing gasket
16	Key	32	Gland half	46	Centring pin	80	O-ring	114	Thrower	207	Stuffing box packing	502	Screwed plug
17	Transmission oil	33	Stuffing box packing	50	Screw shaft	81	Stud	118	Drive shaft	218	O-ring	503	Sealing agent
20	Shaft	34	Stud	60	Oil-level glass	82	Sealing agent	120	Lip seal	245	Lip seal	504	Stud
21	Radial bearing	35	Hexagon nut	61	Gasket	83	Hexagon nut	121	Circlip	301	Coupling rod pin	505	Suction casing
22	Circlip	36	Stuffing box housing	70	Seal housing	84	Venting filter	123	Drive-type pin	302	Coupling rod bush	601	Name plate
23	Circlip	37	O-ring	71	Seal sleeve	85	Seal lubricant	125	Pump shaft	303	Coupling rod bush	602	Dome-headed grooved pin
24	Key	38	Hexagon nut	72	Retainer	86	Sealing agent	131	Bearing cover	304	Retaining sleeve	603	Instruction label for commissioning
25	Sealing cap	39	Spring ring	73	Sealing cap	87	O-ring	132	Gasket	305	Joint grease		
26	Radial bearing	40	Stuffing box casing	74	Bearing nut	101	Key	139	Hexagon head bolt	306	Clamping band		

Pump dimensions, possible branch positions, weights

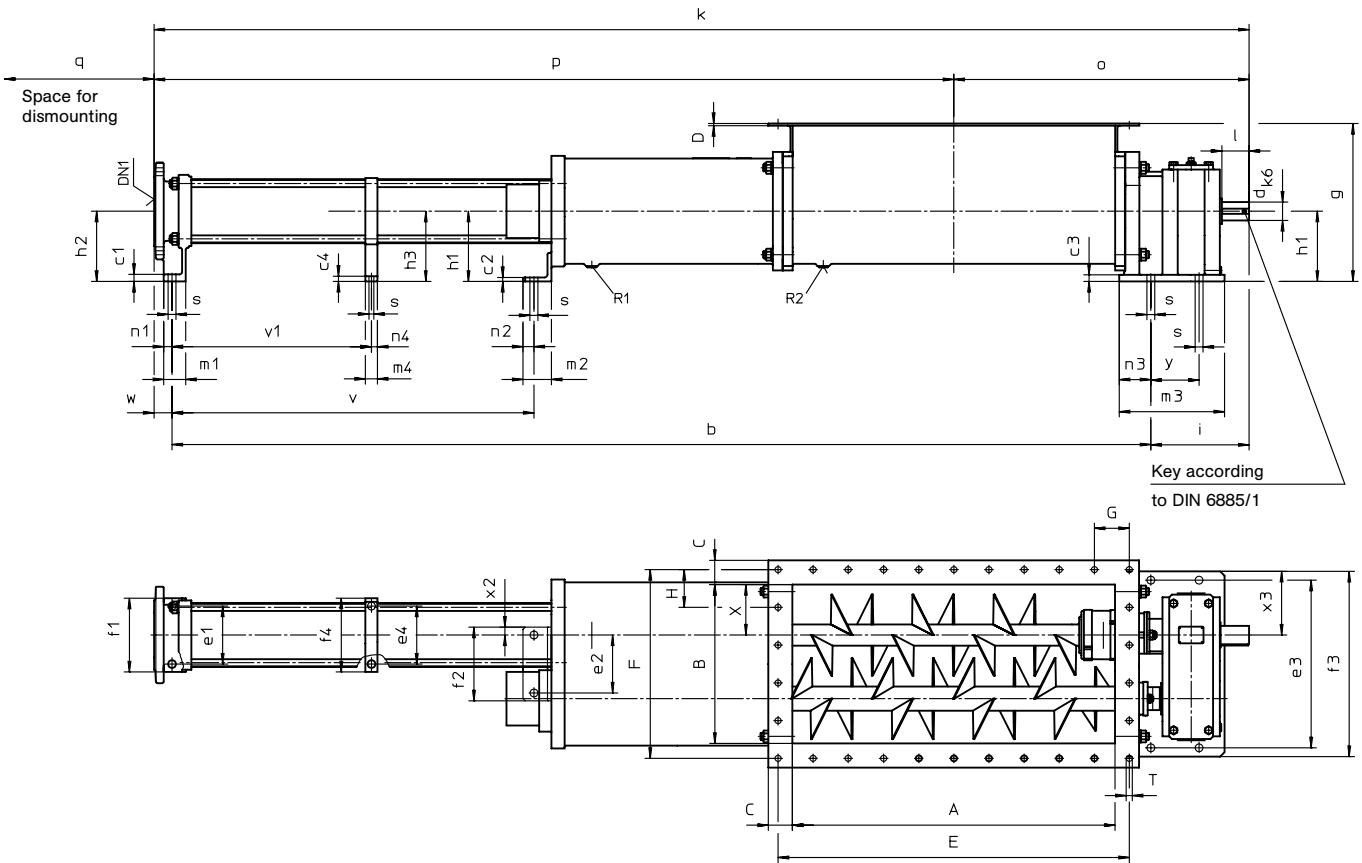

Dimensions of the mating dimensions for suction opening and auxiliary connections R1 and R2 see page 9

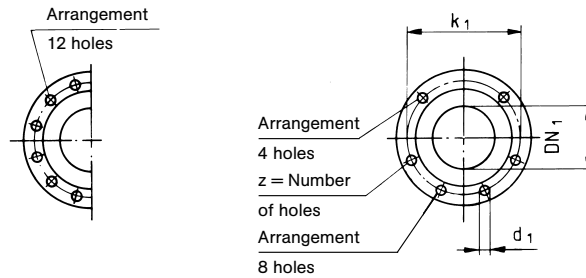

Dimensions in mm, nominal widths of ANSI flanges (DN) in inches. Subject to alterations without prior notice.

Sense of rotation: Counterclockwise looking from the drive end.

Series Size	Pump dimensions																																		
	b	c ₁	c ₂	c ₃	c ₄	d	e ₁	e ₂	e ₃	e ₄	f ₁	f ₂	f ₃	f ₄	g	h ₁	h ₂	h ₃	i	l	m ₁	m ₂	m ₃	m ₄	n ₁	n ₂	n ₃	n ₄	o	q	s	v	v ₁	x ₂	x ₃
AE1N 100-RG	1000.5	13	7	12	-	28	105	105	295	-	137	137	335	-	325	125	125	-	181	50	45	50	210	-	18	18	70	-	405.5	430	14	188	-	16	115
AE2N 100-RG	1200.5	13	7	12	-	28	105	105	295	-	137	137	335	-	325	125	125	-	181	50	45	50	210	-	18	18	70	-	405.5	430	14	388	-	16	115
AE1N 200-RG	1188	14	7	12	-	32	120	120	335	-	155	155	375	-	340	140	140	-	189	60	50	50	220	-	20	18	80	-	453	450	14	243	-	20	130
AE2N 200-RG	1440	14	7	12	-	32	120	120	335	-	155	155	375	-	340	140	140	-	189	60	50	50	220	-	20	18	80	-	453	500	14	495	-	20	130
AE1N 380-RG	1702	15	9	15	-	42	145	145	382	-	185	185	422	-	360	160	160	-	224	65	55	65	240	-	20	25	72	-	673.5	780	18	294.5	-	26.5	145
AE2N 380-RG	2008	15	9	15	-	42	145	145	382	-	185	185	422	-	360	160	160	-	224	65	55	65	240	-	20	25	72	-	673.5	780	18	600.5	-	26.5	145
AE4N 380-RG	2646	15	9	15	-	42	145	145	382	-	185	185	422	-	360	160	160	-	224	65	55	65	240	-	20	25	72	-	673.5	1200	18	123.5	-	26.5	145
AE1N 750-RG	2129.5	17	9	15	-	48	170	170	445	-	215	215	515	-	440	200	180	-	229	75	65	65	265	-	25	25	100	-	789	950	18	396	-	30	180
AE2N 750-RG	2529.5	17	9	15	-	48	170	170	445	-	215	215	515	-	440	200	180	-	229	75	65	65	265	-	25	25	100	-	789	950	18	796	-	30	180
AE4N 750-RG	3359.5	17	9	15	-	48	170	170	445	-	215	215	515	-	440	200	180	-	229	75	65	65	265	-	25	25	100	-	789	1600	18	1626	-	30	180
AE1N 1450-RG	2432.5	20	9	15	-	60	200	200	560	-	250	250	640	-	500	250	225	-	290	80	85	65	320	-	35	25	110	-	867	950	23	514	-	24.5	219.5
AE2N 1450-RG	2937.5	20	9	15	-	60	200	200	560	-	250	250	640	-	500	250	225	-	290	80	85	65	320	-	35	25	110	-	867	1000	23	1019	-	24.5	219.5
AE4N 1450-RG	3983.5	20	9	15	-	60	200	200	560	-	250	250	640	-	500	250	225	-	290	80	85	65	320	-	35	25	110	-	867	2050	23	2065	-	24.5	219.5
AE1N 2700-RG	2921	28	9	15	-	75	290	290	710	-	350	350	790	-	570	280	280	-	342.5	100	80	65	300	-	30	22	110	-	1027.5	1080	27	606	-	40	260
AE2N 2700-RG	3579	28	9	15	-	75	290	290	710	-	350	350	790	-	570	280	280	-	342.5	100	80	65	300	-	30	22	110	-	1027.5	1230	27	1264	-	40	260
AE2+2N 2700-RG	4895	28	9	15	29	75	290	290	710	290	350	350	790	350	570	280	280	280	342.5	100	80	65	300	55	30	22	110	22.5	1027.5	1230	27	2580	1335	40	260

① Space required for stator replacement

Series Size	Mating dimensions for suction opening											R ₁	R ₂	Approx. weight kg
	A	B	C	D	E	F	G	H	T	X				
AE1N 100-RG	290	275	33	5	335	320	67	64	12	85	Rp 1/2	Rp 1/2		
AE2N 100-RG	290	275	33	5	335	320	67	64	12	85	Rp 1/2	Rp 1/2		
AE1N 200-RG	350	315	45	5	410	375	82	75	14	100	Rp 1/2	Rp 1/2		
AE2N 200-RG	350	315	45	5	410	375	82	75	14	100	Rp 1/2	Rp 1/2		
AE1N 380-RG	735	362	55	5	800	430	80	86	14	115	Rp 1/2	Rp 1/2		
AE2N 380-RG	735	362	55	5	800	430	80	86	14	115	Rp 1/2	Rp 1/2		
AE4N 380-RG	735	362	55	5	800	430	80	86	14	115	Rp 1/2	Rp 1/2		
AE1N 750-RG	892	455	55	5	960	522	80	87	14	150	Rp 1/2	Rp 1/2		
AE2N 750-RG	892	455	55	5	960	522	80	87	14	150	Rp 1/2	Rp 1/2		
AE4N 750-RG	892	455	55	5	960	522	80	87	14	150	Rp 1/2	Rp 1/2		
AE1N 1450-RG	892	571	55	5	960	640	80	80	14	185	Rp 1/2	Rp 1/2		
AE2N 1450-RG	892	571	55	5	960	640	80	80	14	185	Rp 1/2	Rp 1/2		
AE4N 1450-RG	892	571	55	5	960	640	80	80	14	185	Rp 1/2	Rp 1/2		
AE1N 2700-RG	1108	720	55	5	1176	783	84	87	14	225	Rp 3/4	Rp 3/4		
AE2N 2700-RG	1108	720	55	5	1176	783	84	87	14	225	Rp 3/4	Rp 3/4		
AE2+2N 2700-RG	1108	720	55	5	1176	783	84	87	14	225	Rp 3/4	Rp 3/4		

Series Size	Mating dimensions for discharge connection																								
	Flanges DIN 2501, PN 16 ②				Flanges ANSI B16.1, Class 125 ③				Flanges ANSI B16.5, Class 150 ③				Flanges DIN 2501, PN 25 ②				Flanges ANSI B16.1, Class 250 ③				Flanges ANSI B16.5 RF, Class 300				
	DN ₁	k	p	w	DN ₁	k	p	w	DN ₁	k	p	w	DN ₁	k	p	w	DN ₁	k	p	w	DN ₁	k	p	w	
AE1N 100-RG	65	1221.5	816	40	-	-	-	-	2 1/2	1221.5	816	40	-	-	-	-	-	-	-	-	-	-	-	-	-
AE2N 100-RG	65	1421.5	1016	40	-	-	-	-	2 1/2	1421.5	1016	40	-	-	-	-	-	-	-	-	-	-	-	-	-
AE1N 200-RG	80	1419	966	42	-	-	-	-	3	1419	966	42	-	-	-	-	-	-	-	-	-	-	-	-	-
AE2N 200-RG	80	1671	1218	42	-	-	-	-	3	1671	1218	42	-	-	-	-	-	-	-	-	-	-	-	-	-
AE1N 380-RG	100	1972	1298.5	46	4	1976	1302.5	50	4	1976	1302.5	50	-	-	-	-	-	-	-	-	-	-	-	-	-
AE2N 380-RG	100	2278	1604.5	46	4	2282	1608.5	50	4	2282	1608.5	50	100	2282	1608.5	50	4	2290	1616.5	58	-	-	-	-	-
AE4N 380-RG	100	2916	2242.5	46	4	2920	2246.5	50	4	2920	2246.5	50	100	2920	2246.5	50	4	2928	2254.5	58	-	-	-	-	-
AE1N 750-RG	150	2403.5	1614.5	45	6	2407.5	1618.5	49	-	-	-	-	-	-	-	-	-	-	-	-	-	-	-	-	-
AE2N 750-RG	150	2803.5	2014.5	45	6	2807.5	2018.5	49	-	-	-	-	150	2809.5	2020.5	51	6	2818.5	2029.5	60	-	-	-	-	-
AE4N 750-RG	150	3633.5	2844.5	45	6	3637.5	2848.5	49	-	-	-	-	150	3639.5	2850.5	51	6	3648.5	2859.5	60	-	-	-	-	-
AE1N 1450-RG	200	2782.5	1915.5	60	8	2787.5	1920.5	65	-	-	-	-	-	-	-	-	-	-	-	-	-	-	-	-	-
AE2N 1450-RG	200	3287.5	2420.5	60	8	3292.5	2425.5	65	-	-	-	-	200	3293.5	2426.5	66	8	3305.5	2438.5	78	-	-	-	-	-
AE4N 1450-RG	200	4333.5	3466.5	60	8	4338.5	3471.5	65	-	-	-	-	200	4339.5	3472.5	66	8	4351.5	3484.5	78	-	-	-	-	-
AE1N 2700-RG	-	-	-	-	-	-	-	-	-	-	-	-	-	200	3349.5	2322	86	-	-	-	8	3380.5	2353	117	-
AE2N 2700-RG	-	-	-	-	-	-	-	-	-	-	-	-	-	200	4007.5	2980	86	-	-	-	8	4038.5	3010	117	-
AE2+2N 2700-RG	-	-	-	-	-	-	-	-	-	-	-	-	-	200	5323.5	4296	86	-	-	-	8	5354.5	4326	117	-

② Sealing surface DIN 2526, shape C, machined acc. to shape A
 ③ Sealing surface: stock finish

Possible branch positions looking from the drive

Flange dimensions																								
DIN 2501, PN 16				ANSI B16.1/16.5, Class 125/150				DIN 2501, PN 25				ANSI B16.1, Class 250				ANSI B16.5, Class 300								
DN ₁	k ₁	d ₁	z	DN ₁	k ₁	d ₁	z	DN ₁	k ₁	d ₁	z	DN ₁	k ₁	d ₁	z	DN ₁	k ₁	d ₁	z	DN ₁	k ₁	d ₁	z	
65	145	18	4	2 1/2	139.7	19	4	-	-	-	-	-	-	-	-	-	-	-	-	-	-	-	-	-
80	160	18	8	3	152.4	19	4	-	-	-	-	-	-	-	-	-	-	-	-	-	-	-	-	-
100	180	18	8	4	190.5	19	8	100	190	22	8	4	200	22.2	8	-	-	-	-	-	-	-	-	-
150	240	22	8	6	241.3	22.2	8	150	250	26	8	6	269.9	22.2	12	-	-	-	-	-	-	-	-	-
200	295	22	12	8	298.4	22.2	8	200	310	26	12	8	330.2	25.4	12	8	330.2	25.4	12	-	-	-	-	-

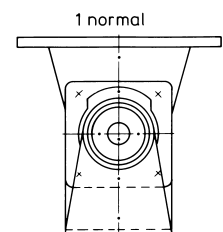

Driving possibilities

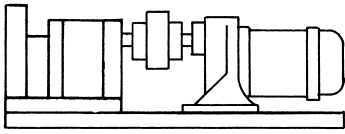

2 AE.N...-RG with flexible coupling and geared motor

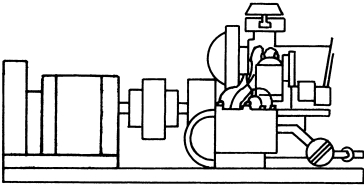

3 AE.N...-RG with flexible coupling and internal combustion engine

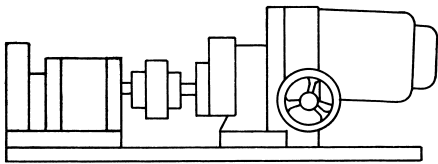

6 AE.N...-RG with flexible coupling and infinitely variable speed drive

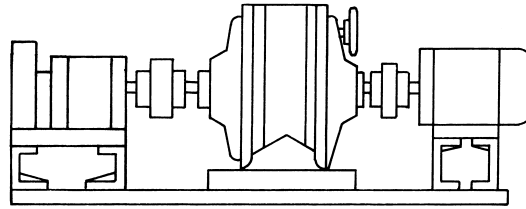

7 AE.N...-RG with flexible coupling, gear box or variable speed gear, flexible coupling and motor

Further drive options (e.g. hydraulic or pneumatic drives) are possible.

Range of eccentric screw pumps	Series	Number of stages	Maximum output at $\Delta p = 0$ bar		Maximum del. pressure bar	Maximum viscosity mPa·s
			m ³ /h	l/min		
	AE.E-ID	1,2	450	7500	10	300.000
	AE.N-ID	1,2	290	4850	16	270.000
	AE.H-ID	2,4	174	2900	24	270.000
	AEB.E-IE	1,2	174	2900	6	300.000
	AEB.N-IE	1,2	111	1850	12	270.000
	AEB4H-IE	4	12	200	24	270.000
	AED.E-ID	1	720	12000	8	250.000
	AED.N-ID	2	450	7500	16	225.000
	AEDB.E-IE	1	258	4300	6	250.000
	AEDB.N-IE	2	174	2900	12	225.000
	AE.N...-RG	1,2,4	30	500	20	1.000.000
	TECFLOW	1	186	3100	4	200.000
	SEZP	1,2	21	350	10	1.000.000
	SNZP	1,2	45	750	12	1.000.000
	SNZBP	1,2	45	750	12	1.000.000
	SSP	1,2	48	800	12	150.000
	SSBP	1,2	48	800	12	150.000
	SETP ①	1,2	140	2350	10	300.000
	SETBP	1,2	40	670	10	150.000
	SEFBP	1	40	670	6	150.000
	SMP	1	40	670	6	150.000
	SMP2	1	5,5	92	6	11.500
	AFP	1	2,8	47	6	50.000
	ANP	2	2,5	42	12	20.000
	ANBP	2	2,5	42	12	20.000
	ASP	2	2,5	42	12	20.000
	ASBP	2	2,5	42	12	20.000
	ADP	3	0,6	10	12	20.000
	ADBP	3	0,6	10	12	20.000
	ACNP	1,2	29	480	12	150.000
	ACNBP	1,2	29	480	12	150.000

① Special versions for higher pressures available.

Peristaltic range	Series	Maximum output		Maximum del. pressure bar	Maximum viscosity mPa·s
		m ³ /h	l/min		
	ASL	2,4	40	4	100.000
	ASH	60	1000	15	100.000

Macerator range	Series	Maximum throughput m ³ /h	Generated delivery head
			m
	AM ... S-1	80 at 3 % solids	3
	ABM ... S-1	80 at 3 % solids	3
	AM ... I-1	160 at 3 % solids	-
	ABM ... I-1	80 at 3 % solids	-

Accessories

Pump accessories: Stator setting devices, electrical heaters, bridge breakers.

Drivers: Electric motors, geared motors, variable speed transmissions, reduction gearboxes, internal combustion engines, pneumatic and hydraulic drives.

Transmission components: Couplings, V-belt transmissions, toothed belt transmissions, other types of transmission.

Base plates: Standard and special versions, wheeled trolleys, mounting flanges.

Safety arrangements: Bypass lines with safety or regulating valves, systems to guard against dry running (conductive, capacitive, thermal etc.).

Other accessories: Electrical, hydraulic and pneumatic control arrangements, filter systems, metering equipment, seal liquid and circulating systems for shaft seals, valves, flanges, flexible pipes.

Subject to technical alterations.



ALLWEILER GmbH
Werk Bottrop

Postfach 200123 · 46223 Bottrop
Kirchhellener Ring 77-79 · 46244 Bottrop
Germany

Tel. +49 (0)2045 966-60
Fax +49 (0)2045 966-679
E-Mail: service-ge@allweiler.de
Internet: http://www.allweiler.com