



# RAINSAFE™

POTABLE WATER FROM RAIN WATER



## WATER TREATMENT SYSTEM



**RainSafe™** is a complete and pre-assembled, plug & play, certified & patented system for purifying harvested rainwater to potable standards.

The system comprises of a recyclable polyethylene tank; an automatic electronic control unit; inlet & outlet filters, UV light & Ozone generator with injection system, customized Eurocom Pump 30/30 M, and Smart Press pump controller.

**The RainSafe™** is energy efficient as the refresh process allowing the UV Lamp to be off for >90% of the day. The unit is supplied with a recyclable white plastic front cover.

- Protection Level:** IP 40
- Working ambient temp:** Min. +5°C to max. +35°C
- Max. Flow:** 50 L/min
- Max. Head:** 46 meters
- Liquid temp range:** from +5°C to max. +35°C
- Max. working pressure of the RainSafe™:** 4.6 bar (460kPA)
- Rainwater inlet:** ≥20 L/min min. 2.5 bar; max. 8.0 bar
- Rainwater inlet connection:** 1" BSP F
- Potable outlet connection:** 1" BSP F
- Overflow / vent connection:** DN50
- Electric connection:** CEE7/5 (Schuko)

## TECHNICAL DATA

MODEL	CODE	PRICE €	ELECTRICAL DATA					HYDRAULIC DATA							N° IMPELLERS	WEIGHT Kg	Q.TY x PALLET	
			VOLTAGE 50 Hz	P1 MAX W	P2 NOMINAL		In A	Q=m³h	0	0,6	1,2	1,8	2,4	3,0				3,6
					kW	HP		Q=l/min	0	10	20	30	40	50				60
<b>RainSafe™ MIDI</b> <sup>(1)</sup>	<b>60153581</b>	<b>3.500</b>	1x220-240V ~	0.720	0.45	0.6	3.2	H (m)	46	42,2	37,8	31,2	23,3	14,3	-	4	60	2

Note: The performances are of the Eurocom 30/30M pump included as part of the RainSafe™; prior to the water leaving the RainSafe™ there is a 10µm carbon filter which will have an affect on the actually performance curve.

<sup>(1)</sup> Available from March 2013

## PARTICOLARS

1	RainSafe™ tank – 230 litres
2	RainSafe™ controller
3	Inlet valve
4	Flow monitor
5	Level switch
6	Inlet 5µm polypropylene filter
7	UV & Ozone generator
8	Venturi
9	Valve
10	Eurocom RS 30/30 M
11	Valve
12	Valve
13	Outlet 10µm carbon filter
14	Smart Press pump controller
15	Valve
16	UV lamp socket
17	Rainwater inlet connection: 1" BSP F
18	Potable outlet connection: 1" BSP F
19	DN50 overflow / vent / refresh connection
20	Electrical connections – CEE7/5 (Schuko plug)
21	Electrical connection to rainwater tank pump*; (Schuko socket)

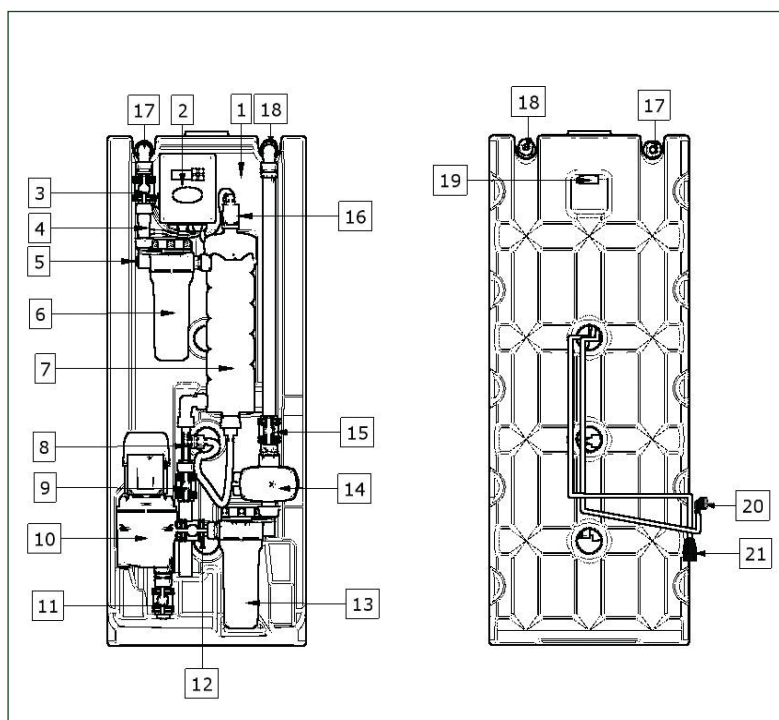

\* rainwater tank pump not included