

# ACF5 Std Line



## Product Description



Flow volume:	310 - 2900 l/min
Max differential pressure:	16 bar
Applications:	Circulation, lubrication and transfer

**ALSO VALID FOR PUMP SERIES UCF Generation 5**

# 1. Applications

## 1.1 Functionality

The ACF/UCF pumps are used for a number of different fluids:

Lubrication oil, fuel oil, vegetable oil, hydraulic oil and any non-aggressive fluid with sufficient lubricating properties.

If requested, the ACF/UCF pump may be certified according to any of following classification societies: DNV, BV, LRS, ABS, RS, GL, RINA, KR, NK, RMR or CCS.

Accuracy of performance according to VDMA 28284 group 2.

## 1.2 Applications

Typical applications are:

- Lubrication of diesel engines, gears, gas and steam turbines, hydro turbines and paper machines
- Main and prelude for diesel engines
- Circulation for cooling and filtration in large machineries and hydraulic systems
- Transformer oil for insulation in transformers
- Transfer onboard vessels, in power plants, oil factories, refineries, tank farms etc
- Filling of pressure chambers in hydraulic presses

## 1.3 Installation

The pump is designed to be flange-mounted to its electric motor via a connecting frame and a flexible shaft coupling. By the connecting frame, the pump may be installed both horizontally and vertically. For vertical installations, a stand called TRIPOD can be supplied.

For pipe connections, standard for ACF series is DIN-type. For UCF, the standard is ANSI. Note that for UCF, a version for vertical installation with feet are available (version xxFx). See section Pump Model code

As standard the pump is delivered with the discharge side to the left when seen from the pump rear end (see below).

For more information about installation, see Installation and Start-up instruction for low pressure pumps.

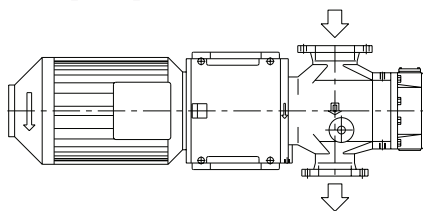

Mounting standard picture M93-0.

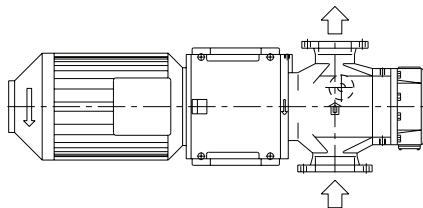

On request the pump can be delivered with opposite flow direction, M39-0.

## 2. Pump model code

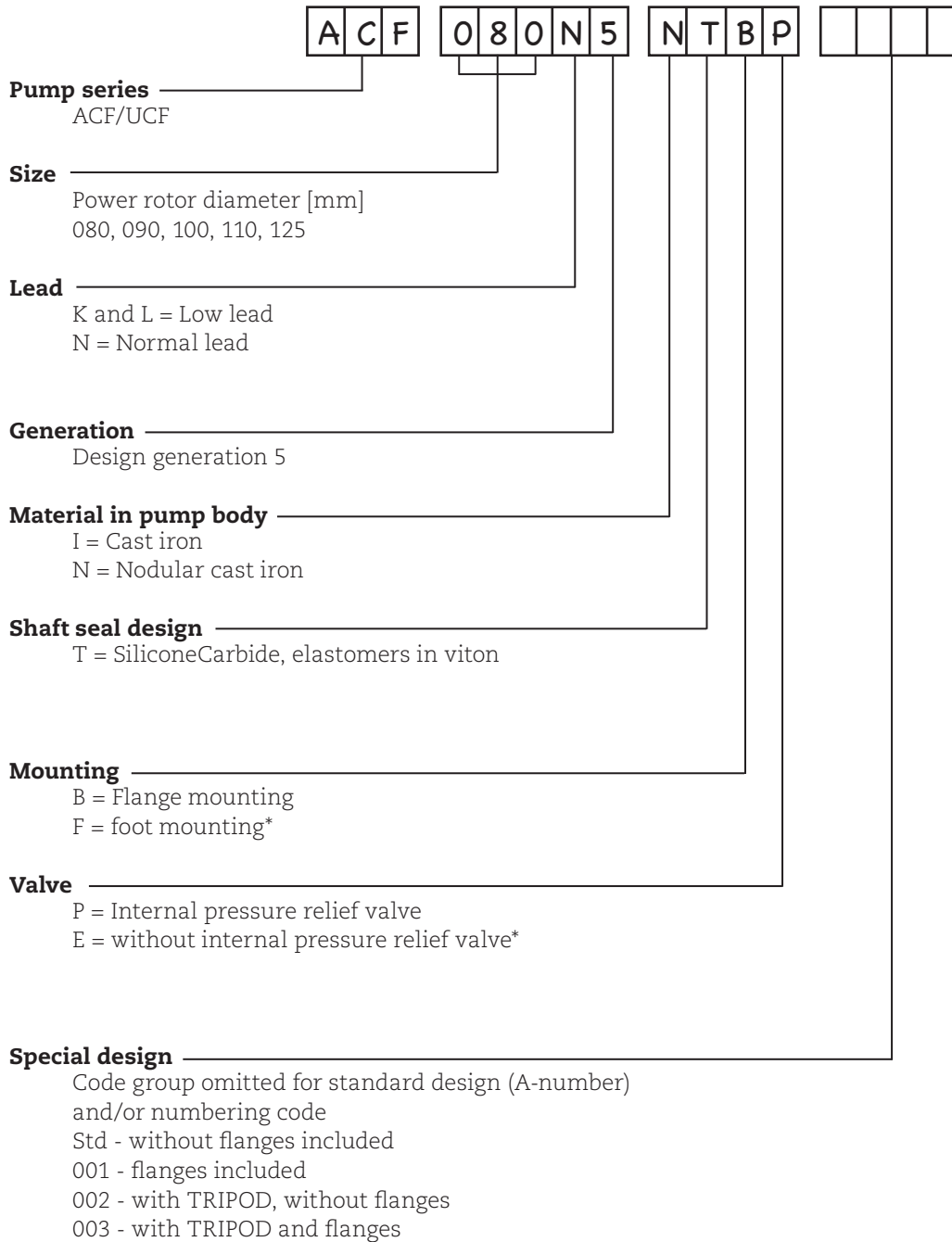

\*Only valid for UCF series

## 3. Technical Data

### 3.1 Pressure Information

#### Pressure relief valve

The pump is equipped with an internal pressure relief valve with internal return, limiting the differential pressure across the pump and protecting the pump. Should the discharge line be blocked, the relief valve will open by the pressure. The valve is adjustable for different opening pressures.

The value of the pressure limit can be set at the factory and should be adjusted at installation (see Installation & Start-up instruction for low-pressure pumps).

The maximum pressure accumulation varies with pump size, speed and viscosity, but will normally not exceed 5 bar.

The valve has a maximum set pressure of 16 bar.

#### Inlet pressure

Minimum inlet pressure (suction capability) is dependent on fluid viscosity and rotation speed. It increases with decreasing viscosity and decreasing speed. Information about minimum inlet pressure for each individual duty case can be obtained from IMO AB or pump selection software WinPump.

Maximum inlet pressure is 7 bar.

#### Discharge pressure

Maximum discharge pressure is 16 bar.

#### Differential pressure

Maximum differential pressure is 16 bar but reduced at low viscosities according to table below

Viscosity [cSt]	1,4	2	6	10	>38
Max. diff. pressure [bar]	4,3	5	7,7	9,5	16

Refer to your IMO representative or use the pump selection software WinPump to determine the exact operating limits.

### 3.2 Driver information

#### Driver type

The pump is designed to be connected to an electrical motor via a flexible shaft coupling.

Under certain conditions, other types of drive can be permitted, e.g. gear or pulley drives, which create radial loads onto the shaft end.

For radial load requirements, contact IMO AB.

#### Speed

The maximum speed is 1800 rpm. Maximum operating speed may be reduced depending on inlet conditions. Contact IMO or use the pump selection software WinPump to find a corresponding speed limit in order to avoid cavitation problems. For information about cavitation see section IMO Tuning.

#### Rotation

The pump is designed to operate in one rotational direction only, as standard clockwise when facing the shaft end. Pumps for CCW operation can be delivered on special request.

For shorter periods of time, a few minutes for emptying a discharge line, the pump may be operated in reverse direction, provided the back pressure is limited to 3 bar.

## 3. Technical Data

### 3.3 Sound level

Typical pump sound levels refer to free field conditions at a distance of 1 m from the pump. Noise of driver excluded in the quoted figures. The sound levels are measured at a discharge pressure of 7 bar, speed 1450 rpm and viscosity 37 cSt.

Pump Size	080	090	100	110	125
Sound level dB[A]	73	74	75	76	77

### 3.4 Moment of Inertia

Size	080	090	100	110	125
[10 <sup>-3</sup> kgm <sup>2</sup> ]	5,3	8,2	17,2	24,6	43,9

### 3.5 Fluid viscosity

1,4 – 5000 cSt.

### 3.6 Fluid temperature

Cast Iron version (Ixxx): -20 – +90 °C

Nodular Cast Iron version (Nxxx): -20 – +130 °C

## 4. Design

### 4.1 Ball bearing

The pump is fitted with internal ball bearing which continuously is being greased by the handling media.

### 4.2 Material & design

Model	Material pump	Material rotor	Material idler	Material seal	Material Elastomers
ACF I/ UCF I	Grey cast iron	Structural steel, surface treated	Structural steel, surface treated	SiliconCarbide (SiC/SiC)	Viton
ACF N/ UCF N	Nodular (ductile) cast iron	Structural steel, surface treated	Structural steel, surface treated	SiliconCarbide (SiC/SiC)	Viton

*For handling of fluids which may be aggressive to above materials, consult IMO AB.*

## 5. Performance Guide

Typical performance values at 5 bar  
Flow calculated at 26 cSt, power at 260 cSt.

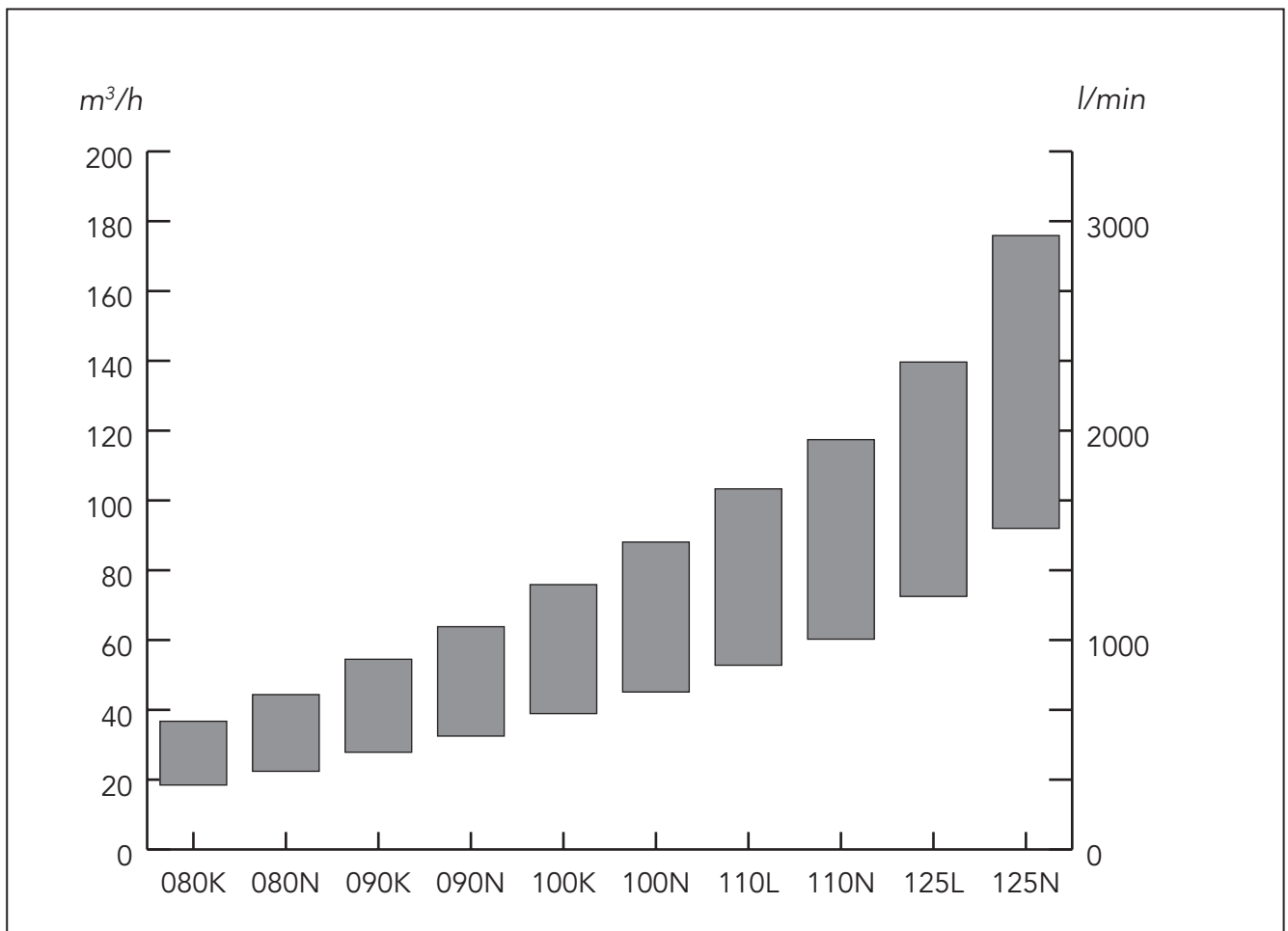

<b>080K</b>			<b>080N</b>			<b>090K</b>			<b>090N</b>		
rpm	l/min	kW	l/min	kW	l/min	kW	l/min	kW	l/min	kW	
950	308	4,7	373	5,7	464	6,9	541	8,1			
1150	384	5,9	465	7,1	575	8,6	672	10,2			
1450	498	7,8	602	9,4	742	11,4	868	13,4			
1750	612	9,8	739	11,8	908	14,3	1 064	16,8			
<b>100K</b>			<b>100N</b>			<b>110L</b>			<b>110N</b>		
rpm	l/min	kW	l/min	kW	l/min	kW	l/min	kW	l/min	kW	
950	649	9,5	752	11,1	880	9,5	1 004	11,1			
1150	803	12,0	931	13,9	1 090	12,0	1 242	13,9			
1450	1 034	15,8	1 200	18,4	1 406	15,8	1 600	18,4			
1750	1 265	19,9	1 468	23,1	1 722	19,9	1 957	23,1			
<b>125L</b>			<b>125N</b>								
rpm	l/min	kW	l/min	kW							
950	1 208	9,5	1 533	11,1							
1150	1 488	12,0	1 883	13,9							
1450	1 908	15,8	2 407	18,4							
1750	2 328	19,9	2 932	23,1							

# 6. Sectional view

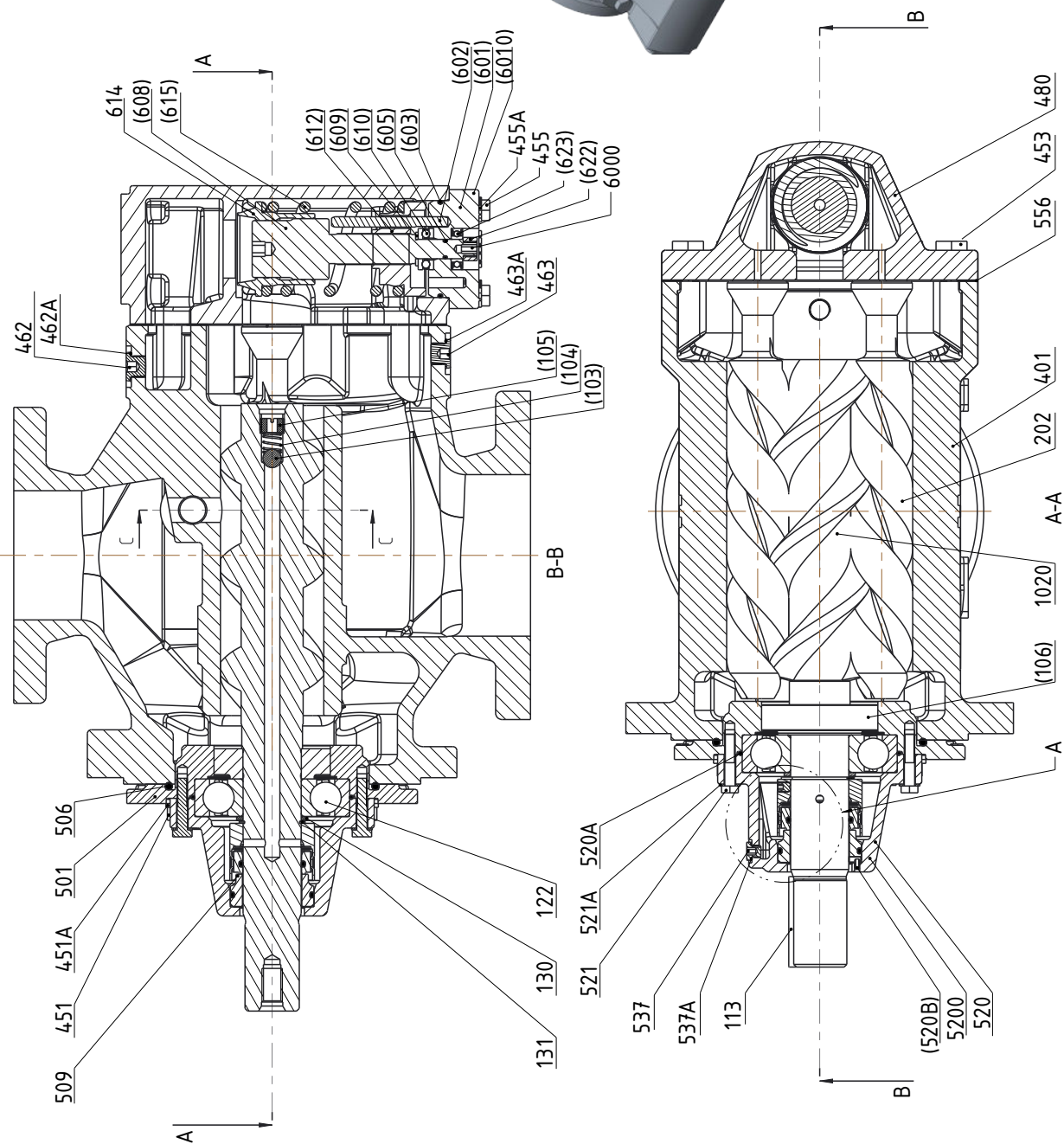
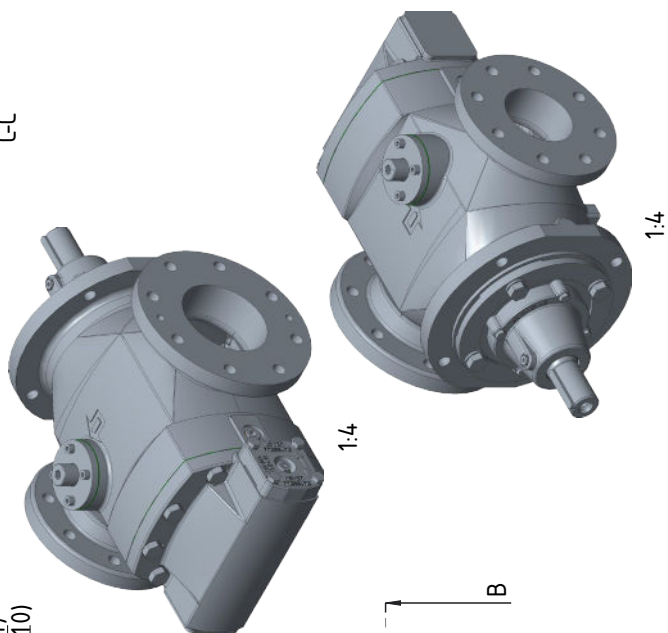
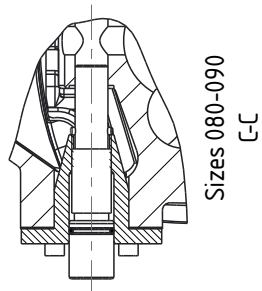
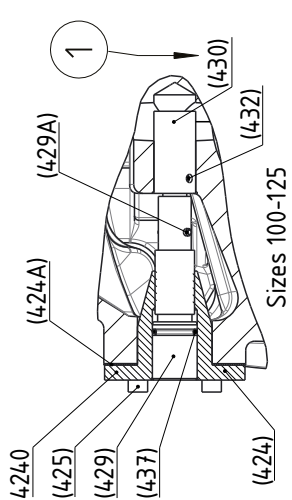



## 7. List of Components

Pos No	Denomination	Pos No	Denominat	Pos No	Denomination
1020	Complete power rotor	451	Screw	(520B)	Tension pin
(103)	Ball	451A	Washer	(537)	Deaeration plug
(104)	Spring	453	Screw	(537A)	Sealing washer
(105)	Hole	455	Screw	520A	O-ring
(106)	Balancing piston	455A	Washer	521	Screw
113	Key	462	Plug	521A	Washer
122	Ball bearing	462A	Sealing washer	556	Gasket
130	Support ring	463	Plug	6000	Complete valve element
131	Retaining ring	463A	Sealing washer	(6010)	Complete valve cover
202	Idle rotor	480	Valve housing	(602)	Pin
401	Pump body	501	Front cover	(603)	O-ring
4240	Complete tuning element	506	O-ring	(605)	O-ring
(424)	Cover	509	Complete shaft seal	(608)	Valve spindle
(424A)	Gasket	S1	Stationary seat	(609)	Washer
(425)	Screw	S2	Stationary seat O-ring	(610)	Ball bearing
(429)	Guiding screw	S4	Seal ring	(612)	Regulating nut
(429A)	Tension pin	S5	Seal ring carrier	(614)	Valve piston
(430)	Piston	S6	Seal ring O-ring	(615)	Valve spring
(432)	Tension pin	5200	Complete cover	(622)	Nut
(437)	O-ring	(520)	Cover	(623)	Ball Bearing

Drawing remarks:

(1) Applicable for sizes 100-125

Notes:

- Components with Pos No within parenthesis are parts of subassembly

# 8. Pump Dimensions

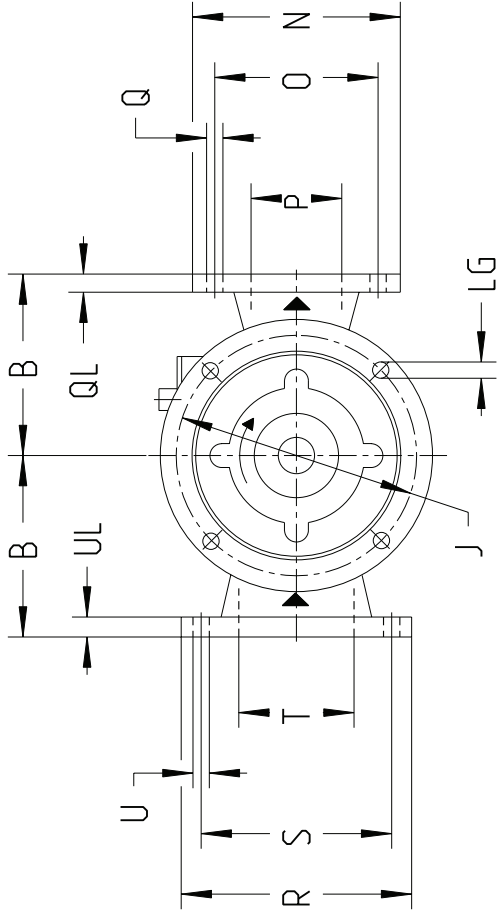
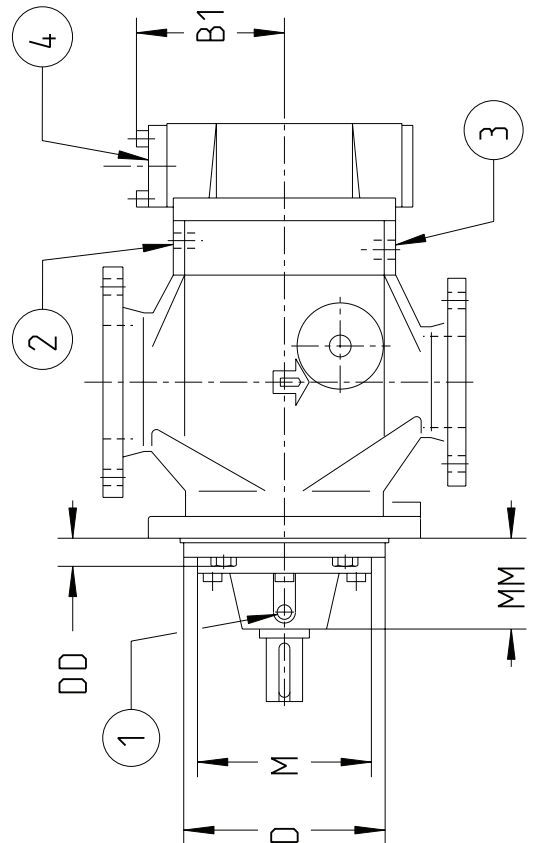
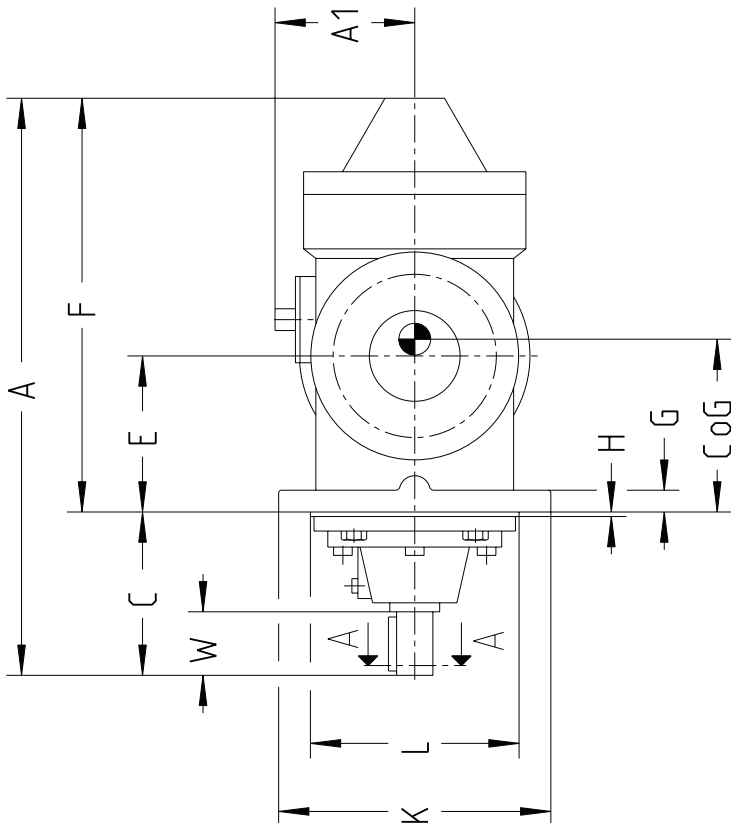

Size 080

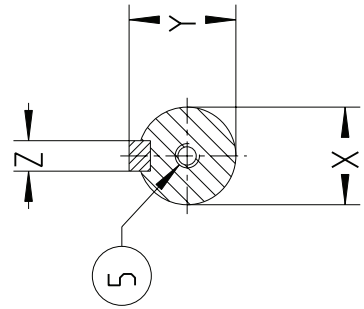

A-A

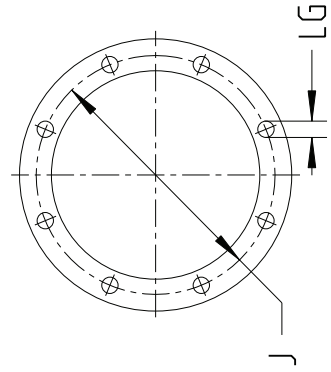

Sizes 090-125



# 9. Pump Unit dimensions

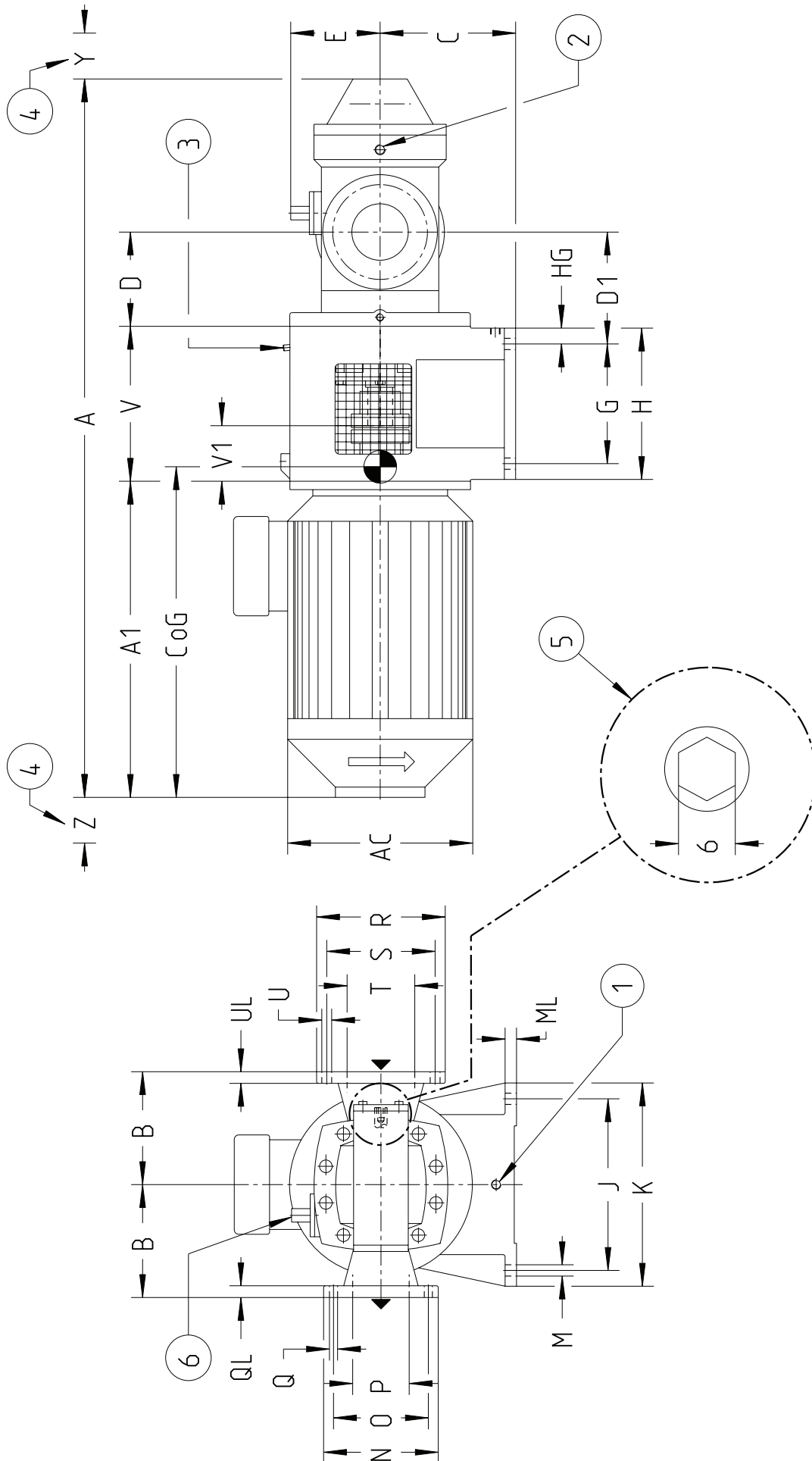



## 10. Accessories

A bare shaft pump (Fig. 1) can be ordered with the accessories in fig. 2-7.

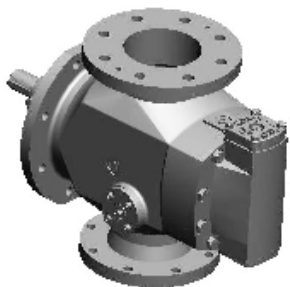

Fig. 1 Bare shaft pump



Fig. 2 Set of counter flanges

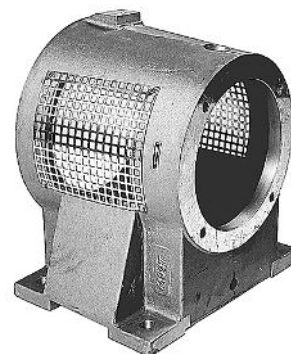

Fig. 3 Connecting frame

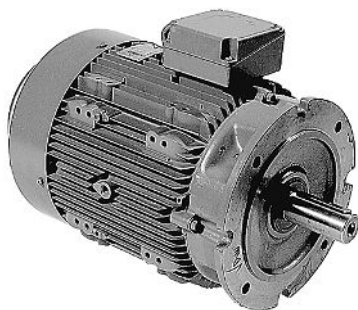

Fig. 4 Electric motor



Fig. 5 Shaft coupling

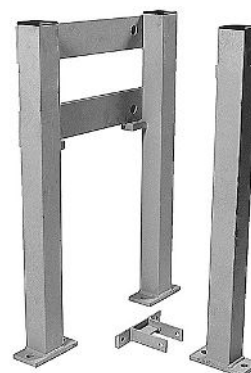

Fig. 6 Tripod



Fig. 7 Gauge panel

## 11. Maintenance and Service

Spare parts for these pumps are easily available from stock. For detailed information and know-how about service, see the Maintenance & Service Instruction for ACF5/UCF5 pumps or contact IMO AB.

## 12. IMO AB Tuning

The tuning® valves, which are standard on the ACF/UCF series, make it possible to pump oil containing free air, with a minimum of disturbing vibration noise.

Low volume lube oil systems and additives that prolong deaeration time are the main reasons for having an excessive amount of free air in the oil. Free air is the main source of vibration and noise in pump systems as the air entrained oil is compressible and air bubbles expand and decrease in size very rapidly. By throttling the tuning® valve, the correct amount of fluid, depending on air content and pressure, is fed from the pressure side into the rotor bores.

The effect this has on the air bubbles is that they will gradually decrease in size rather than collapse when exposed to the full pressure on the discharge side.

### 12.1 Effect of tuning® Pressure fluctuations

#### Without tuning

Pressure fluctuations are rapid and cover a wide band which produces a loud ratting noise.

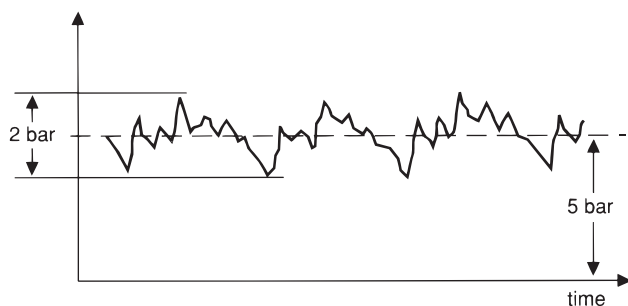

#### With tuning

Pressure fluctuations are highly reduced in speed and magnitude leading to low noise level. Diagram refers to tests at 1800 rpm, delivery pressure 5 bar, inlet pressure -0,5 bar, viscosity 75 cSt and 6 % free air.

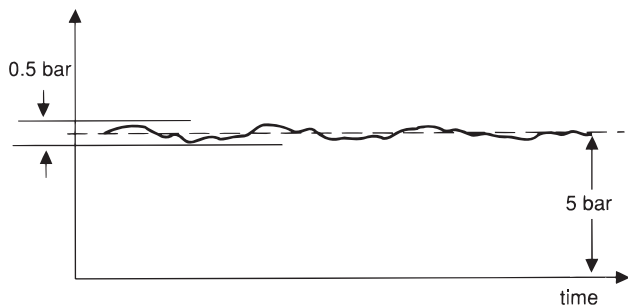

The two tuning® valves on the pump are easily adjusted individually (by turning the tuning spindles with an Allen key to a position where the noise level comes to a minimum) while the pump is working under normal operating conditions.

**For latest updates, check:  
[www.imo.se](http://www.imo.se)**